

## Application Note

### 20/21D436 20/21D439 High Resolution Color Camera Module



**Prior to Using This Document:** Videology reserves the right to modify the information in this document as necessary and without notice. It is the user's responsibility to be certain they possess the most recent version of this document by going to [www.videologyinc.com](http://www.videologyinc.com), searching for the model number, and comparing revision letters on the respective document, located in the document's footer.

**For technical assistance with this product, please contact the supplier from whom the product was purchased.**

**Videology Imaging Solutions, Inc. USA**  
37M Lark Industrial Parkway  
Greenville, RI 02828  
Tel: 401-949-5332  
Fax: 401-949-5276



**Videology Imaging Solutions, B.V. Europe**  
Neutronenlaan 4  
NL-5405 NH Uden, Netherlands  
Tel: +31 (0) 413-256261  
Fax: +31 (0) 413-251712

Doc # APN 20/21D43x	Issue Date: 12/19/2008
Revision: H	Page 1 of 18

## Table Of Contents

1.	Document History.....	3
2.	Introduction .....	3
3.	Features .....	3
3.1.	White Balance Mode .....	4
3.2.	Fixed Shutter Speeds .....	4
3.3.	Synchronization Modes .....	5
3.4.	Gain Control.....	6
3.4.1.	AGC .....	6
3.4.2.	Manual Gain Control .....	6
3.5.	Gamma .....	6
3.6.	Back Light Compensation .....	6
3.7.	Non-interlaced.....	7
3.8.	Frame Rate .....	8
3.9.	Outputs .....	8
4.	Software Control .....	9
4.1.	Camera Software Protocol .....	9
4.2.	Camera Configuration.....	10
4.3.	I <sup>2</sup> C address .....	11
4.4.	Communication Reset.....	11
4.5.	Command Registers .....	12
4.6.	EEPROM Special Settings .....	14
5.	Mechanics/Connectors.....	15
5.1.	Board Outline .....	15
5.2.	Connectors .....	16
5.3.	13 Pin Connection Table.....	16
6.	Specification .....	17
7.	Contact Information.....	18

## 1. Document History

Revision	Issue Date	Reason	CN#
Rev A	2003-03-21	Initial derived from 20D479	03-0062
Rev B	2003-04-01	New protocol added	03-0043
Rev C	2003-09-13	BLC update and change	03-0044
Rev D	2003-09-24	Embedded software change	04-0128
Rev E	2003-12-04	Updated Specification Chart	04-0156
Rev F	2004-03-24	Technical specs changed	04-0161
Rev G	2008-07-21	Removed line lock option	08-0143

## 2. Introduction

The 20/21D439 is a high resolution color camera module with a CS-mount lens interface. The basic module is a single board camera with a high resolution CCD and several extra features. The state of the art components in the 20/21D439 provide superb image quality. Multiple features and small size of 42 x 42 mm allow for usage in almost every application.

This document is written to give technical background on specific features of this camera.

## 3. Features

All on main single camera board

Standard basic features:

- CCD horizontal 768/752 pixels, resolution 460 TVL
- Integrated Auto Exposure Control (Iris/AGC)
- Edge enhancement
- Fixed gamma (0.45)
- Sensitivity 50 IRE lens F1.2: 0.5 lux

Additional features of the 20/21D439 main board are:

- Several outputs possibility:
  - CVBS 20D439
  - Y/C (S-VHS) 20D439YC
- Synchronization modes:
  - Internal X-tal locked
- Fixed shutter speeds (8 values including flicker-less)
- Manual gain control (via I<sup>2</sup>C control software)
- Back light compensation on/off (default off)
- Supply voltage +12V DC (+ 3V / - 4V)
- Push Lock White Balance
- Mirror mode on/ off selectable via software
- Computer controllable\*

\*Software to control the camera available on request.

\*Also requires I<sup>2</sup>C conversion board for PC control. Call Videology for details.

Doc # APN 20/21D43x	Issue Date: 12/19/2008
Revision: H	Page 3 of 18

The following basic functions are possible with the 20/21D439 camera module:

### 3.1. White Balance Mode

Via software you can select 2 fixed modes or the Auto White balance mode.

Also you can select via software the "Push to Set" WB mode. This is in fact also a fixed mode. The white balance then is set via pressing (or via software) the button on the back and pointing the camera to a white scene.

### 3.2. Fixed Shutter Speeds

In default mode, the camera operates in the electronic iris mode. This means the output of the CCD, which is dependent on the light intensity, is controlled by the electronics of the camera and not the mechanics of the lens. To do this the camera has an OFD pulse. When this OFD pulse is active ((Low) see figure 1) the charge that is built up in the photo diodes is dumped into the substrate of the CCD. So after each OFD pulse the accumulation of the charge in the photocells of the CCD start from zero. The strength of the CCD signal is dependent on the light intensity and the time that the charge can build up (the period during which no OFD pulse is present).

Therefore, by measuring the output of the CCD and comparing it with an internal reference it is possible to control the level of the signal out of the CCD (within a certain tolerance).

However, sometimes it is preferred that the shutter is fixed and not automatic. An example where using a fixed shutter is beneficial is if there is a very fast moving object in the scene. The longer the integration time (the period that no OFD pulse occurs, max 1/50 sec for PAL and max 1/60 sec for NTSC) the less sharp the image will be due to movement of the object during the integration period. To prevent this the camera has 8 fixed shutter speeds (see table 1). To switch the electronic iris off there are two options: Either via I<sup>2</sup>C software control or via hardware control. For the hardware control mode it is necessary to program the camera module through the software (command setting 06h should be loaded with FFh to force the camera in hardware control).

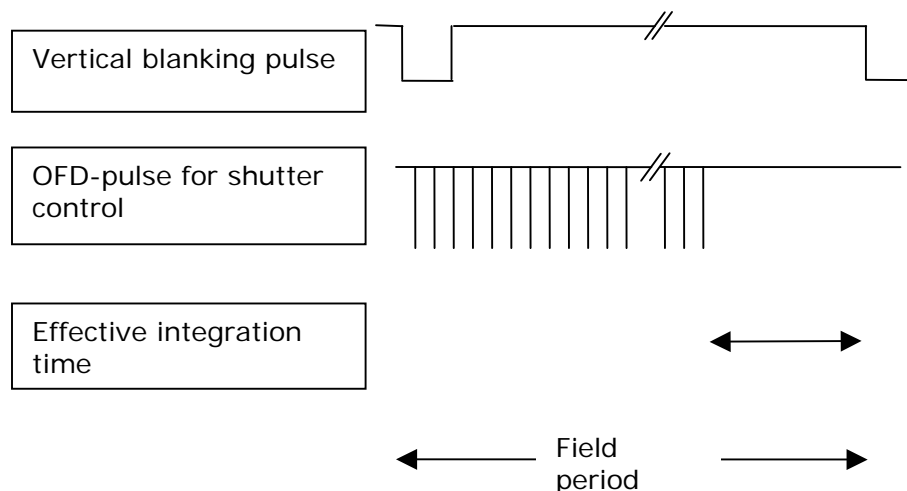

Figure 1. OFD Shutter Control

Shutter speed		Command address 06h
20D439 (NTSC)	21D439(PAL)	
Auto mode		0x00
1/60 sec (max)	1/50 (max)	0x01
1/100 sec (flickerless)*	1/120 sec (flickerless)*	0x02
1/250 second		0x03
1/500 second		0x04
1/1000 second		0x05
1/2000 second		0x06
1/10000 second		0x07
1/20000 second		0x08
1/50000 second		0x09
1/100000 second		0x0a
1/30 second	1/25 second	0x0b
1/15 second	1/12.5 second	0x0c
1/7.5 second	1/6.25 second	0x0d

Table 1. Fixed Shutter Speed

Flickerless means that a PAL camera can be used in a 60 Hz (or a NTSC camera in a 50 Hz) light environment without flickering. This mode can also be used to reduce side effects when the camera is used with fluorescent light environment. This Flickerness Mode may also be set to help minimize white balance drift when used in a fluorescent environment.

When using the extended integration times (1/30, 1/15 or 1/7.5 second) you will have to consider that these integration times will exceed normal video timing. This means that this will result in blinking video due to the missing fields. This mode is used to increase sensitivity of the camera even more. To get full advantage of these modes you need to use video-memory (to get continuous video) or use a capture board.

### 3.3. Synchronization Modes

The camera has two types of oscillators: A crystal for the internal synchronization mode, and an inductor for the external modes.

### 3.4. Gain Control

#### 3.4.1. AGC

The camera has an automatic gain control in the default mode. This function is responsible for the output signal remaining constant at a certain level. If the camera is pointed to a gamma reflection chart 0.45 the output should be 1 Vp-p. This control circuit works with an integrator. This integrator generates from the video signal a signal that corresponds with the average value of the signal. This average is compared with an internal reference and depending on the outcome of the gain will increase or decrease.

#### 3.4.2. Manual Gain Control

If a fixed or manual gain control is desired, then the I<sup>2</sup>C interface may be used to command register 07h with a value from 80h (0dB) to FFh (maximum level). All values above 80h are fixed values. Below 80h the gain control is automatic.

### 3.5. Gamma

A camera has a gamma function to correct the non-linear behavior of the monitor CRT. The gamma curve of the camera is 0.45. With this gamma setting the monitor is able to display the scene as we see it with our eyes.

However, if the camera video signal is processed for pattern recognition this gamma function is often not wanted. To make this possible the 20/21D439 has a gamma option, this can be programmed via I<sup>2</sup>C serial interface. Contact Videology for details. This is like this because the 20D439 has no command function for gamma.

### 3.6. Back Light Compensation

The camera has a default setting of standard back light compensation (BLC) off.

When switched on (by pulling pin 4 of connector J3 to ground or via software control). It means that for the electronic iris circuit only a (selectable) part of the scene is taken into account to determine the level of the CCD output (see figure 3). When fixed shutter speeds are used this function has no effect.

By default command 03h has the value of FFh, this means that the camera is default on hardware control. To set BLC on pin 4 of connector J3 must be pulled to ground.

When command register 03h is set to 00h then the BLC is switched on. Changing the setting of register 98h in EEPROM page 2 (a2/a3) you can change the weighting factor of the BLC function, this is the relation factor between the chosen window and the rest of the picture (default this value is 30h).

Size and position of BLC window can be changed by changing command register 08h and 09h.

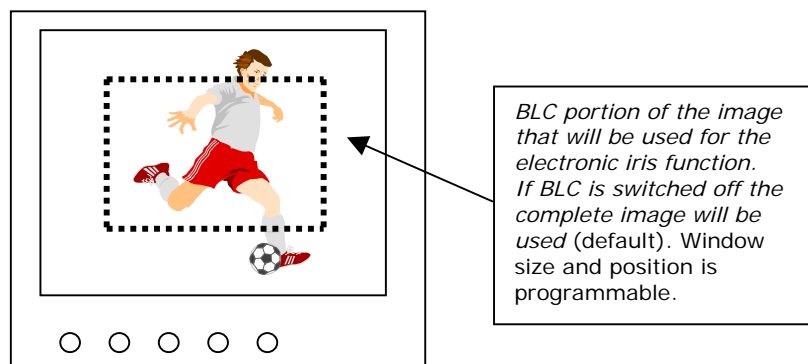

Figure 2. Back Light Compensation

Doc # APN 20/21D43x	Issue Date: 12/19/2008
Revision: H	Page 6 of 18

### 3.7. Non-interlaced

The camera normally runs in the interlaced mode according to the PAL or NTSC standard. This means that a full picture (frame) is built up out of two half pictures (fields) who are shifted half a line referenced to each other. For a graphical view see figure 4.

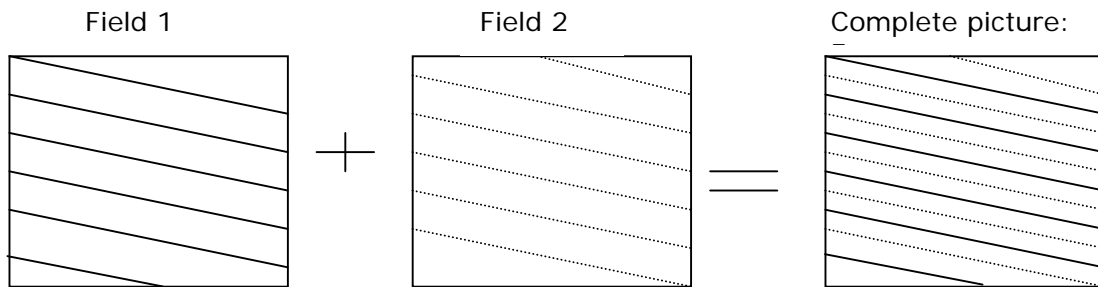

Figure 3. Interlaced Display

This means that every 40ms (for PAL) or 33.3ms (for NTSC) the camera generates a complete picture.

However, sometimes the application does not require high vertical resolution, but must have the same information from each field (without the half line shift between the fields). In that case the two fields are identical to each other. See figure 5.

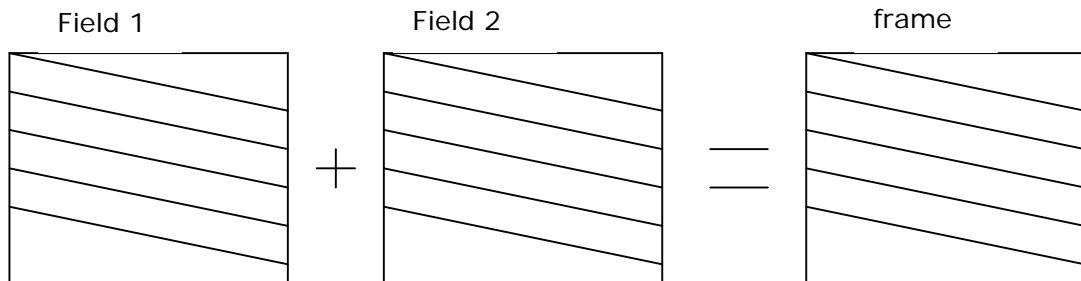

Figure 4. Non-Interlaced Display

In figure 5 it can be seen that the vertical resolution is less compared to the interlaced mode (see figure 4), but that the fields are identical with each other and therefore the frame rate is increased (doubled).

To put the camera in the non-interlaced mode send FFh to command register 0Ah.

### 3.8. Frame Rate

The camera's normal operation is according to the NTSC or PAL standard. However the components are selected in such a way that by increasing the main clock frequency, the vertical frequency can be increased up to 75 Hz. To achieve the new frequency the crystal should become:

Camera	Vertical frequency: 75 Hz
20D439 (NTSC)	35.795 MHz
21D439 (PAL)	42.56 MHz

Table 2. Crystal Frequencies

The crystal should be a standard type (fundamental).

### 3.9. Outputs

Via Hardware changes several output formats can be selected:

- CVBS standard output, type number 20D439
- Y/C (SVHS) output, type number 20D439YC



## 4. Software Control

### 4.1. Camera Software Protocol

The camera has a serial control interface via three wires:

- Data wire
- Clock wire
- Ground wire

This interface operates similar as to the I<sup>2</sup>C-protocol.

Data, address and registers are all 8 bit words. Graphical the interface is shown in figure 6.

The maximum speed limitation is 10kHz. The minimum speed should be higher then 100Hz. The write action to the EEPROM needs to be done with a waiting time between the write actions of at least 10msec.

Further a wait time is required between the commands, so that the internal communication has the time to do the required internal communication. The delay time between the commands should be at least 2msec.

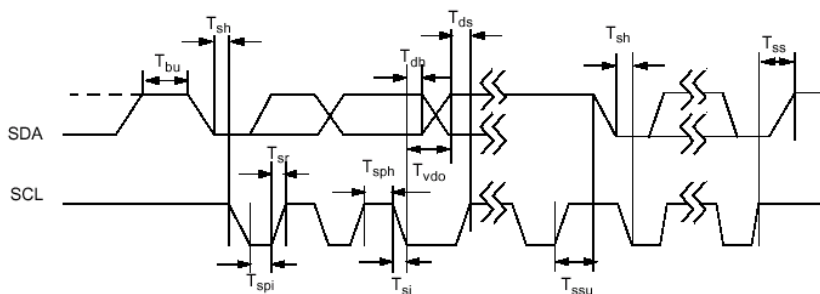

Figure 5. Communication Timing

Standard I<sup>2</sup>C address camera: 0x70

The communication-structure contains a Command block and a Data block.

Command block:

**<START> <cam\_address>ackn<acces\_mode>ackn<device>ackn  
<register>ackn<STOP>**

Cam_address	Acces_mode	device
Standard=0x70*	00=write to camera 01=read to camera 09=dump (write) EEPROM**	00=encoder 30=DSP 40=commands a0,a2,a4,a6= EEPROM

Data block(if acces\_mode !=09, accesmode is not configured as dump-mode):

**<START><cam\_addressR/W>ack<data>ackn/Nackn\*\*\*<STOP>**

Cam_address	Data:
Access mode=00: 0x70	Write data to camera with ackn
Access mode=01: 0x71	Read data from camera with NOT ackn.

\*The address can be changed. In address 0xa0 of the EEPROM: 0xa2 is the address of camera stored. Camera can get new address if customer wants/needs!

\*\*Special mode to access EEPROM faster for production. Block writing possible not every time camera address required. First both passwords have to be given before access is allowed!

\*\*\*NOT acknowledge means: master send a clock low→high→low as with a normal acknowledge, but camera may not respond by pulling data line low. This must be checked otherwise the number of bits are not correct!

#### 4.1.1.1. Example 1 write action

Set white balance mode to Push to White, this means:

Command 40; register 00 and data 03:

Write action:

Command-block:

<start> 70 ackn 00 ackn 40 ackn 00 ackn <stop>

datablock:

<start> 70 ackn 03 ackn

description: camera-address 70, access mode write, device 40 (command), register 00,

datablock: write address 70 , data 03.

#### 4.1.1.2. Example 2 Read action

Command 40; register 00 and read data :

Read action:

Command-block:

<start> 70 ackn 01 ackn 40 ackn 00 ackn <stop>

datablock:

<start> 71 ackn data (returned) Nackn

description: camera-address 70, access mode read, device 40 (command), register 00,

datablock: read address 71 , camera will sent data.

## 4.2. Camera Configuration

The device addresses have two values, one for read the other one for write. The difference is that the last bit (LSB) is set to one. For the communication the next device addresses are available:

Device	Device write	Device read
DSP	0x30	Not possible
Commands	0x40	0x41
EEPROM page 1	0xa0	0xa1
EEPROM page 2	0xa2	0xa3
EEPROM page 3	0xa4	0xa5
EEPROM page 4	0xa6	0xa7

Table 3.

Device addresses

Table 4.

Doc # APN 20/21D43x	Issue Date: 12/19/2008
Revision: H	Page 10 of 18

It is not possible to read from the DSP. The DSP is a write only device.  
Don't write to the DSP because it can make the camera non-functional.

EEPROM pages 3 and 4 are protected by a password! The normal user may not have access to these two pages since the back up settings and production date is saved in here.

The DSP settings are directly mapped on EEPROM page 1.

The camera will recognize several commands. Often these will be a combination of several internal commands to fulfill a certain task. To send commands to the camera, first the device number 0x40 has to be sent. After that the command (at the place normally the address will be found) must be sent. And third is the data.

#### 4.3. I<sup>2</sup>C address

The camera has an I<sup>2</sup>C address so that more than one camera can be connected to I<sup>2</sup>C bus. **Default the camera has address 0x70.** In case user might have forgotten the new address he can reset it back to the factory default by connecting pin 16 of the micro processor (port 0.5, test-point available on board) to ground.

Connect to ground for at least 4 seconds.

The I<sup>2</sup>C address is stored in the EEPROM page 2 address 0x90 (hex).  
To change this address one should write: device 0xa2; address 0x90; value 0xXX, where XX is a hex value from 0-FF. With this method you can have 256 different I<sup>2</sup>C addresses for the camera.

With device 0xa3 one can read the value.

#### 4.4. Communication Reset

Sometimes it can happen that communication is halted. The u-processor then will reset the communication lines.

Doc # APN 20/21D43x	Issue Date: 12/19/2008
Revision: H	Page 11 of 18

#### 4.5. Command Registers

To address the command 40h has to be send. Direct after that the command register and value.

The following commands can be executed.

For more detail please see the readme.doc which is with the SW-package.

command	Command register address	Data range
White balance mode	0x00	0x00 auto white balance 0x01 fixed white balance mode 1 0x02 fixed white balance mode 2 0x03 push to white
Not used	0x01	Not used
Not used	0x02	Not used
Back light comp.	0x03	0x00= BLC on 0xFF= BLC off and hardware control
RESET: load defaults	0x04	0xac= reset load default values
Mirror mode	0x05	0x00=normal, 0xff=mirror
Shutter mode	0x06	0x00= electronic iris 0x01= 1/50 or 1/60 sec 0x02= flickerless 0x03= 1/250 0x04=1/500 0x05=1/1000 0x06=1/2000 0x07=1/10000 0x08=1/20000 0x09=1/50000 0x0a=1/100000 0x0b=1/25 or 1/30 sec (intermittent Frame readout) 0x0c=1/12.5 or 1/15 sec (intermittent Frame readout) 0x0d=1/6.25 or 1/7.5 sec (intermittent Frame readout) 0xff= hardware control 8 values!
Gain control	0x07	0x00= auto mode 0x80= fixed gain minimal 7 LSB's are fixed gain: The MSB indicates fixed gain 0xff= fixed gain maximal gain
Non-interlaced	0x0a	0x00= interlaced 0x0f=non-interlaced 0xff=hardware control
Edge enhancement	0x0b	0xc0 edge enhancement off gain range 0x00 up to 0x1F
Standby	0x0c	0x00= DSP active, 0xff DSP standby after a power down and up the camera will start , does not stay in standby.

BLC window can be programmed for special light situations:

Size BLC window	0x08	64 windows can be defined over the whole active pixels. This means that for PAL: H = 94 pixels and V = 72 pixels ; For NTSC: H= 96 pixels and V = 62 pixels. Size H x V 0x00 1H x 1V 0x01 1H x 2V 0x02 1H x 4V 0x03 1H x 8V 0x04 2H x 1V 0x05 2H x 2V 0x06 2H x 4V 0x07 2H x 8V 0x08 4H x 1V 0x09 4H x 2V 0x0A 4H x 4V 0x0B 4H x 8V 0x0C 8H x 1V 0x0D 8H x 2V 0x0E 8H x 4V
Position BLC window ( 9 window positions possible)	0x09 (See also figure below)	0x00 center 0x01 Top left 0x02 Top center 0x03 Top right 0x04 Center left 0x05 Center right 0x06 Bottom left 0x07 Bottom center 0x08 Bottom right

1	2	3
4	0	5
6	7	8

Figure 6. BLC Position

The BLC weighting factor can also be programmed. The value of this factor (which in fact is a number which determines how the ratio between window and the rest of the image is calculated) is stored in EEPROM, see table on next page.

The command settings are stored inside the memory of the camera. After a power down the camera will come up with the last used settings again (except standby).

#### 4.6. EEPROM Special Settings

The fixed white balance settings are programmed in EEPROM. These values can be altered.

<b>Address in EEPROM page 0xA2/A3</b>	<b>Content</b>
0x91	Fixed white balance mode 1 BLUE
0x92	Fixed white balance mode 1 RED
0x93	Fixed white balance mode 2 BLUE
0x94	Fixed white balance mode 2 RED
0x95	Fixed white balance mode 3 BLUE
0x96	Fixed white balance mode 3 RED
0x97	Push to White correction factor
0x98	BLC weighting factor

## 5. Mechanics/Connectors

This chapter gives the mechanical information about the 20/21D439. This mechanical information includes also connector information.

### 5.1. Board Outline

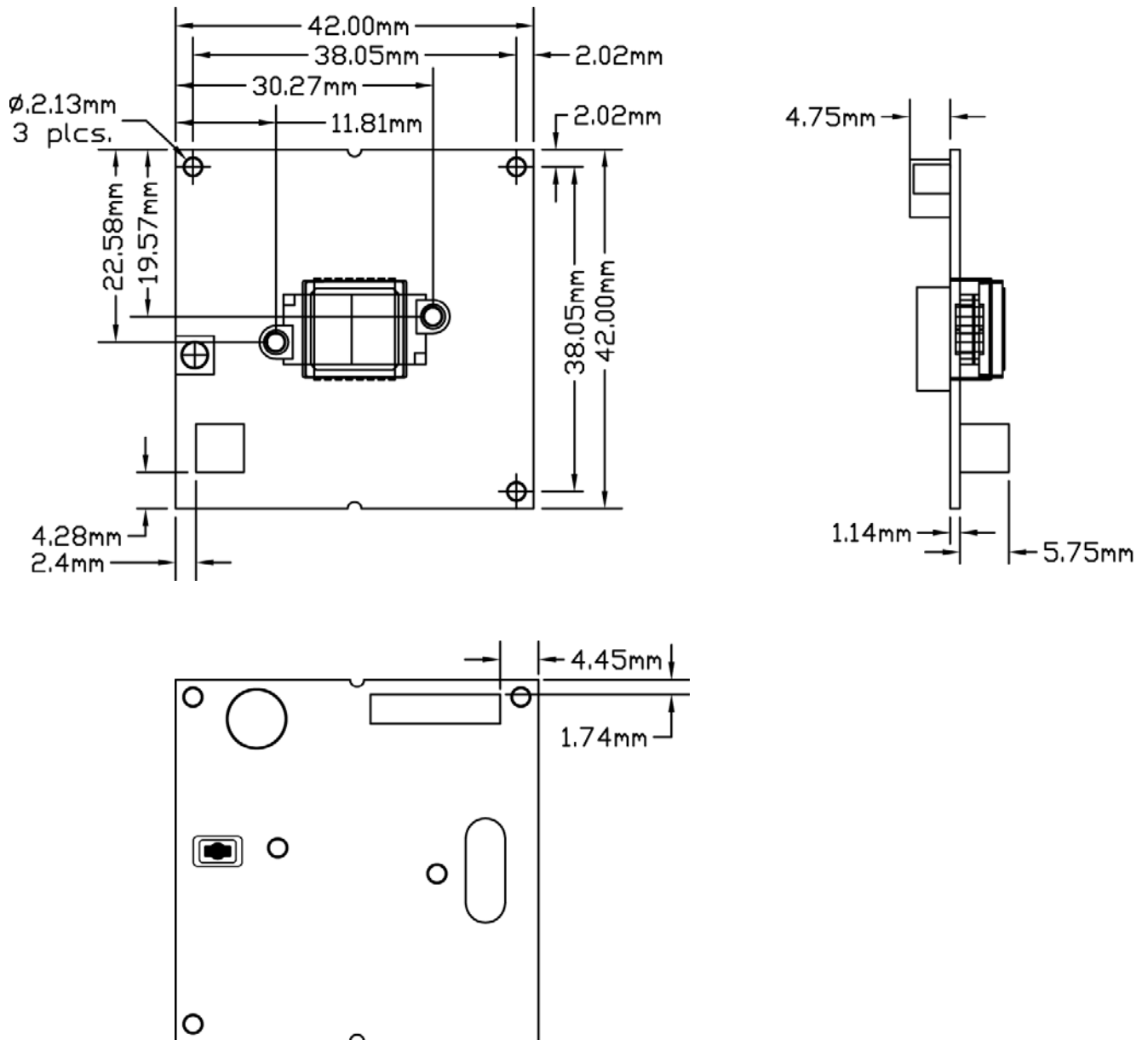

Figure 7. Board Mechanics

Doc # APN 20/21D43x	Issue Date: 12/19/2008
Revision: H	Page 15 of 18

## 5.2. Connectors

The camera has one connector that can be used as interfaces for the user of the camera. Both are located at the backside of the camera (see Figure 8).

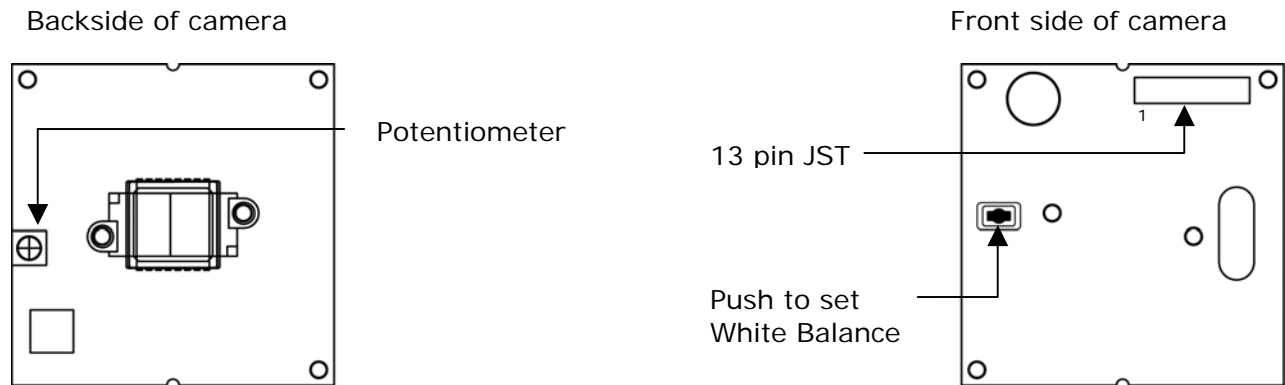

Figure 8. Connectors

J730 is a 13-pole JST connector, type BM13B.

## 5.3. 13 Pin Connection Table

Pin number	Pin function J730
1	NOT CONNECTED
2	GND
3	+12V IN
4	Back Light Compensation (Ground to turn on)
5	GND
6	NOT CONNECTED
7	CVBS (in case of Y/C this output is Y)
8	C-OUT (in case of Y/C)
9	VEXT
10	EE (when connected to ground then Electronic shutter is off)
11	IRISout
12	SDATA
13	SCLOCK (black wire)



## 6. Specification

<b>Electrical</b>	<b>20D436 / 20D439 NTSC</b>	<b>21D436 / 21D439 PAL</b>
CCD Sensor	1/3" IL	
Active Pixels (H x V)	768 x 492	752 x 582
Horizontal Resolution	460 (TVL) CVBS	
Sensitivity	0.5 Lux (50 IRE) F1.2, 3200 <sup>0</sup> K, lens transmission 80%, scene reflection 75%	
Signal to Noise Ratio	> 48 dB (AGC off)	
Gamma	Default 0.45	
Gain	Automatic (36 dB default)	
Synchronization	Internal	
Back Light Compensation	Off (Default) hardware/ software select	
White Balance	Push to set and auto, software select	
Shutter Speed	Automatic from 1/60 to 1/100,000	Automatic from 1/50 to 1/100,000
	Fixed shutter hardware/ software select	
Mirror Mode	On/Off selectable via software	
Iris	CCD Iris default / video iris	
Video Output	1Vp-p video 75 ohms composite	
Power Supply	12VDC (+3 -4) (Polarity protected)	
Power Consumption	1.7W excluding: auto iris power consumption	

### Environmental

Ambient Operating Temp.	-15° C ~ 55° C (5° F ~ 131° F)
Storage Temp.	-25° C ~ 70° C (-13° F ~ 158° F)

### Mechanical

Dimensions WxHxD	42mm x 42mm x 25mm (1.65" x 1.65" x 0.98")	
Lens Mount	20D436 / 21D436	Metal M-12 board lens mount with reference plate 12mm diameter, 0.5mm pitch
	20D439 / 21D439	Metal CS mount with reference plate: Optional C mount with interface ring 60VZZ0030
Interfaces	13 Pole JST	

### Board Mount Lens Options

Specify "L3" suffix for 2.9mm lens (example: 20D436L3)	
L4	3.6mm
L6	6mm
L8	8mm
L12	12mm
VA	4~9 No Iris Varifocal
VB	4~9 DC Iris Varifocal
WA	2.6~5.6 No Iris Varifocal
WB	2.6~5.6 DC Iris Varifocal

### Accessories

Optional	24VAC power board
----------	-------------------

## 7. Contact Information

**For technical assistance with this product, please contact the supplier from whom the product was purchased.**

For OEM inquiries, contact Videology Imaging Solutions:

<b>North / South America:</b>	<b>Europe:</b>
Videology Imaging Solutions Inc. 37M Lark Industrial Parkway Greenville, RI 02828 USA Tel: (401) 949-5332 Fax: (401) 949-5276	Videology Imaging Solutions Europe Neutronenlaan 4 NL-5405 NH Uden, Netherlands Tel: +31 (0) 413 256 261 Fax: +31 (0) 413 251 712

Please visit our WEB-site at: <http://www.videologyinc.com/>

**VIDEOLOGY IMAGING SOLUTIONS** is an ISO 9001 registered video camera developer and manufacturer serving industrial, machine vision, biometric, security, and specialty OEM markets. Videology designs, develops, manufactures, and distributes video, image acquisition, and display technologies and products to OEMs worldwide.