

VIDEOLOGY

IMAGING SOLUTIONS INC.
Original Equipment Manufacturer

Application Note Linux Driver Software Release 1.0.1

SFT-11020	20/21K1XXUSB-C
SFT-11021	24B1.3XUSB-C
SFT-11022	24C1.3XUSB
SFT-11023	60V002USB-C

Prior to Using This Document: Videology reserves the right to modify the information in this document as necessary and without notice. It is the user's responsibility to be certain they possess the most recent version of this document by going to www.videologyinc.com, searching for the model number, and comparing revision letters on the respective document, located in the document's footer.

For technical assistance with this product, please contact the supplier from whom the product was purchased.

Videology® Imaging Solutions, Inc.



37M Lark Industrial Parkway
Greenville, Rhode Island 02828 USA
Tel: (401) 949 – 5332 Fax: (401) 949 – 5276
North/South American Sales: sales@videologyinc.com
www.videologyinc.com

Videology® Imaging Solutions, Europe B.V.

Neutronenlaan 4
NL-5405NH Uden, The Netherlands
Tel: +31 (0) 413 256261 Fax: +31 (0) 413 251712
European Sales: info@videology.nl
www.videology.nl

License Agreement (Software):

This Agreement states the terms and conditions upon which Videology Imaging Solutions, Inc. USA and Videology Imaging Solutions, B.V. Europe (hereafter referred to as "Videology®") offer to license to you the software together with all related documentation and accompanying items including, but not limited to, the executable programs, drivers, libraries, and data files associated with such software.

The Software is licensed, not sold, to you for use only under the terms of this Agreement.

Videology grants to you, the purchaser, the right to use all or a portion of this Software provided that the Software is used only in conjunction with Videology's family of products.

In using the Software you agree not to:

- Decompile, disassemble, reverse engineer, or otherwise attempt to derive the source code for any Product (except to the extent applicable laws specifically prohibit such restriction);
- Remove or obscure any trademark or copyright notices.

Limited Warranty (Hardware and Software):

ANY USE OF THE SOFTWARE OR HARDWARE IS AT YOUR OWN RISK. THE SOFTWARE IS PROVIDED FOR USE ONLY WITH VIDEOLOGY'S HARDWARE. THE SOFTWARE IS PROVIDED FOR USE "AS IS" WITHOUT WARRANTY OF ANY KIND, TO THE MAXIMUM EXTENT PERMITTED BY LAW, VIDEOLOGY DISCLAIMS ALL WARRANTIES OF ANY KIND, EITHER EXPRESS OR IMPLIED, INCLUDING, WITHOUT LIMITATION, IMPLIED WARRANTIES OR CONDITIONS OF MERCHANTABILITY, QUALITY AND FITNESS FOR A PARTICULAR APPLICATION OR PURPOSE. VIDEOLOGY IS NOT OBLIGATED TO PROVIDE ANY UPDATES OR UPGRADES TO THE SOFTWARE OR ANY RELATED HARDWARE.

Limited Liability (Hardware and Software):

In no event shall Videology or its Licensor's be liable for any damages whatsoever (including, without limitation, incidental, direct, indirect, special or consequential damages, damages for loss of business profits, business interruption, loss of business information, or other pecuniary loss) arising out of the use or inability to use this Software or related Hardware, including, but not limited to, any of Videology's family of products.

Table of Contents

1.	Document History.....	4
2.	The Videology USB Camera Family	4
3.	Installing and Using the Camera	4
3.1.	Installation.....	4
3.2.	Minimum System Requirements.....	4
3.3.	Camera Driver Installation Procedure	5
3.3.1.	Linux (Ubuntu) Installation Procedure	5
3.3.2.	Camera Driver Installation Procedure.....	6
4.	Using the viewers	10
5.	Cameras & Features supported.....	11
6.	Understanding Your Camera	12
6.1.	Theory of Operation	12
6.2.	IR/OLP Options.....	13
6.3.	Glossary of Terms	15
6.3.1.	Shutter Mode.....	15
6.3.2.	Mirror Mode.....	16
6.3.3.	Reset	16
6.3.4.	Gain	16
6.3.5.	White Balance Mode	16
7.	Troubleshooting guide	17
8.	Camera Specifications	18
8.1.	20/21K13XUSB-C	18
8.2.	20/21K14XUSB-C	19
8.3.	20/21K15XUSB-C	20
8.4.	24B1.3xUSB-C.....	21
8.5.	24C1.3USB	22
8.6.	60V002USB-C	23
9.	Contact Information.....	24

1. Document History

Revision	Issue Date	Reason	CN#
Rev A	07-22-12	Initial release	12-0094

2. The Videology USB Camera Family

Videology USB Cameras provide a quick and easy means of displaying and capturing high quality video and images on any USB 2.0 equipped desktop or laptop computer running a supported Linux operating system (Version 2.6.32 or later).

Designed with flexibility in mind, each camera model has its own distinct advantage over the others, whether speed, resolution, image quality, sensitivity or price. Because they are USB based, there is no need for a frame grabber. Instead, a single USB cable provides power, video frames, control and data transfer.

All cameras have a unique driver that accesses the various features of each camera.

Housings: Mechanical design options can be quoted for OEMs

3. Installing and Using the Camera

3.1. Installation

The Videology USB 2.0 High-Speed camera is designed to operate out of the box with minimal set-up.

The software drivers can be found on the CD-ROM that shipped with the product or downloaded from the Videology Imaging Solutions, Inc. website. (Note: Please verify driver is the most recent by checking the Videology Web site.)

Various Viewers can be obtained from different websites:

Viewer	Website
VLC	www.videolan.org/vlc/index.html
Cheese	http://linux.softpedia.com/get/Multimedia/Graphics/Cheese-28762.shtml
Luvcvview	http://luvcvview.sourceforge.net

3.2. Minimum System Requirements

A Personal Computer (PC) with USB 2.0 compatible port

- Full D1 MPEG 2 - P4 – 2.4GHz or above
- 640 x 480 MPEG 2 - P4 – 2.0GHz or above
- 352 x 288 MPEG1 - P4 – 1.5GHz or above
- Hard Disk - 5400RPM or above (7200RPM preferred)
- 256 MB of RAM (512 MB preferred)

Verify your system has a certified Linux Kernel based system. The cameras requires GSPCA driver (General Software Package for Camera Adapters) which is shipped by default with 2.6.26 and later Linux kernels.

3.3. Camera Driver Installation Procedure

3.3.1. Linux (Ubuntu) Installation Procedure

There is a known issue where an ISOC error is encountered when the camera starts streaming. This results in many dropped frames and slow frame rate. There is a kernel patch to resolve this issue "gspca_main-ISOC-error.patch" which must be applied to the base gspca_main driver. You must rebuild and re-install your kernel or gspca_main module, depending on if gspca_main is a module or kernel built-in. Occasionally, Videology cameras may generate an ISOC error and the driver may not handle it properly.

This results in many dropped frames and the following error being printed:

```
gspca: ISOC data error: [3] len=1024, status=-71
```

The error is harmless and should be ignored, however, if not patched the error message will fill up the debug log. A kernel patch is provided to work around this issue (gspca_main-ISOC-error.patch). Apply this patch and rebuild the gspca_main driver as follows:

(1) cd to your kernel directory
i.e. "cd linux-2.6.34"

(2) Apply the patch
i.e. "patch -p1 < gspca_main-ISOC-error.patch"
This patch may need to be done manually depending on which version of Linux loaded on the computer system.

(3) Rebuild the module
i.e. "make drivers/media/video/gspca/gspca_main.ko"
and then reinstall the gspca_main.ko module

(4) Don't forget to reload the gspca_main driver
i.e. "rmmod gspca_main; modprobe gspca_main.ko"

Optionally the entire kernel and modules can be built and installed after the patch is applied (the traditional way). See the kernel documentation for details if you are not familiar with how to do this.

The drivers for each camera need to be installed independently. This is covered in the next paragraph.

Camera	Product feature	Software driver
2xK132, 2xK135, 2xK138	B/W Hi Resolution camera	SFT-11020
2xK142, 2xK145, 2xK148	Color Med Resolution Camera	SFT-11020
2xK152, 2xK155, 2xK158	Color Hi Resolution Camera	SFT-11020
2XD758USB-C	Color Hi Resolution Camera	SFT-11020
20B1.3xUSB-C	Mega pixel B/W Camera	SFT-11021
20C1.3xUSB	Mega pixel color Camera	SFT-11022
6xV002USB-C	Frame Grabber	SFT-11023

3.3.2. Camera Driver Installation Procedure

3.3.2.1. Installation for SFT-11020 for 2xK13, 2xK14, 2xK15, 2xK758

Requires GSPCA driver (General Software Package for Camera Adapters) which is shipped by default with 2.6.26 and later Linux kernels and available as an out of tree for older kernels at

<http://mxhaard.free.fr/download.html>

Note that the kernel header files for the kernel you intend to run must already be installed. "Make" needs these headers to build this driver.

To build:

```
'make'
```

To install:

```
'make install'
```

Load the GSPCA driver (if not already loaded):

```
'modprobe gspca_main'
```

Load the Videology driver:

```
'modprobe gspca_videology_interlaced' OR  
'insmod path>/gspca_videology.ko'
```

Additional notes:

Some viewers require the first pixel to be shifted one byte so that pixel aligns right. Otherwise the colors are reversed and the image color looks clearly wrong. To work around this use the "frame_offset=1" as a module parameter when loading the module.

I.e. `insmod gspca_videology_interlaced.ko frame_offset=1`

3.3.2.2. Installation for SFT-11021 for the 24B1.3x

Requires GSPCA driver (General Software Package for Camera Adapters) which is shipped by default with 2.6.26 and later Linux kernels and available as an out of tree for older kernels at

<http://mxhaard.free.fr/download.html>

Note that the kernel header files for the kernel you intend to run must already be installed. "Make" needs these headers to build this driver.

To build:

```
'make'
```

To install:

```
'make install'
```

Load the GSPCA driver (if not already loaded):

```
'modprobe gspca_main'
```

Load the Videology driver:

```
'modprobe gspca_videology_24B' OR
```

```
'insmod gspca_videology_24B.ko'
```

Additional note:

Controlling the settings by means of the viewer control is very reliable but response takes a few seconds to engage via I2C.

Doc # APN-1102X Linux Drivers	Issue Date: 10-25-12
Revision: A	Page 7 of 24

3.3.2.3. Installation for SFT-11022 for the 24C1.3x

Requires GSPCA driver (General Software Package for Camera Adapters) which is shipped by default with 2.6.26 and later Linux kernels and available as an out of tree for older kernels at

<http://mxhaard.free.fr/download.html>

Note that the kernel header files for the kernel you intend to run must already be installed. "Make" needs these headers to build this driver.

To build:
 'make'

To install:
 'make install'

Load the GSPCA driver (if not already loaded):
 'modprobe gspca_main'

Load the Videology driver:
 'modprobe gspca_videology' OR
 'insmod gspca_videology.ko'

Additional notes:

- The *VLC* viewer seems to support only full format (1280x1024); To use half format (640x480), use "Cheese" as a different viewer. In Cheese just go under preferences to change the format size. Also, *Cheese* has no *V4L2* controls for some reason, so you will need a utility in this package for the controls:

<http://downloads.xskernel.org/soft/linux-src/uvcvideo-553dfd853cba.tar.bz2>

Just open a console/terminal and use the *v4l2-ctl* utility (in *v4l2-apps/util*).

Usage:

to get a list of controls: *v4l2-ctl -l*
to set a control (like exposure): *v4l2-ctl -c exposure=2000*

A good starting point when testing us *gain=10 exposure=3000*.

- Using *VLC* can give CPU load related problems (high processing time). This is because *VLC* renders images directly (render within the application), and the higher the framerate, the higher the CPU load. When this is an issue, then try *lucvview* instead, or some other viewer that does not try and render the image itself (it renders through Xwindows, and the Xserver does the work).

Doc # APN-1102X Linux Drivers	Issue Date: 10-25-12
Revision: A	Page 8 of 24

3.3.2.4. Installation for SFT-11023 for the 60V002USB-C

Requires GSPCA driver (General Software Package for Camera Adapters) which is shipped by default with 2.6.26 and later Linux kernels and available as an out of tree for older kernels at

<http://mxhaard.free.fr/download.html>

Note that the kernel header files for the kernel you intend to run must already be installed. "Make" needs these headers to build this driver.

To build:
 'make'

To install:
 'make install'

Load the GSPCA driver (if not already loaded):
 'modprobe gspca_main'

Load the Videology driver:
 'modprobe gspca_videology_framegrabber' OR
 'insmod <path>/gspca_videology_framegrabber.ko'

Additional notes:

Some viewers require the first pixel to be shifted one byte so that pixel aligns properly. Otherwise the colors are reversed and the image color looks clearly wrong. To work around this use the "frame_offset=1" as a module parameter when loading the module.

I.e. "insmod gspca_videology_framegrabber.ko frame_offset=1"

Alternately, the sysfs entry
/sys/module/gspca_videology_framegrabber/parameters/frame_offset) maybe used instead.

I.e. "echo 1 > /sys/module/gspca_videology_framegrabber/parameters/frame_offset"

The value passed in indicates how many bytes to shift. Typically a value between 1 to 3 is used.

Note: Format size is usually set by the viewer. This sometimes means you need to specify the height/width to the viewer via the command line in order to select the proper format.

There is an additional module parameter that forces the viewer to start in a specific format.

Be forewarned that if this is set > 0, the height/width that the viewer requests will be ignored.

Doc # APN-1102X Linux Drivers	Issue Date: 10-25-12
Revision: A	Page 9 of 24

This can be set via `set_format.sh` script or by writing to the `/sys` entry.

I.e. `"echo 0 > /sys/module/gspca_videology_framegrabber/parameters/default_mode"`
To allow the viewer to select format size. This is the default behavior.

`"echo 1 > /sys/module/gspca_videology_framegrabber/parameters/default_mode"`
To force PAL 724x486.

`"echo 2 > /sys/module/gspca_videology_framegrabber/parameters/default_mode"`
To force NTSC 724x486.

`"echo 3 > /sys/module/gspca_videology_framegrabber/parameters/default_mode"`
To force NTSC 724x576.

4. Using the viewers

Not every viewer will work well with every camera, certain cameras are progressive scan and others are interlaced. VLC usually will work with all of our cameras but not all features are supported.

For VLC you must select the capture device.
To find out what devices are available type the following:

```
ls /dev/video*
```

This will provide a list of devices with a video prefix.
There are 3 viewers that are used in the Linux world, VLC, Cheese, and Luvcview.
They need to be downloaded from their respective websites and compiled on your system to watch video.

Using VLC

To use VLC, either type `vlc` from the active Linux window or select it from the drop down menu.

To open the device, select Media, when the media window opens, select Open Capture Device.

For the Video device name, enter `/dev/videox` – note if you have more than 1 video device, you may have to change the x to 0-4.

To set control settings, select Tools, then Effects and Filters and V4L2 Control.

Using Cheese

To use Cheese, either type Cheese from the active Linux window or select it from the drop down menu.

If you use the drop down menu Cheese expects to find the video device on `video0`.

If you are using the active Linux window type
`Cheese /dev/videox` where x is the video device

Using Luvcview

To use Luvcview, type `luvcview` in the active Linux window.

When you are using the active Linux window type
`luvcview /dev/videox` where x is the video device

5. Cameras & Features supported

Linux Kernel Version		2.6.34
Present version		2.6.35.14
Ubuntu Version		10.10

	Feature VLC	Supported
SFT-11020 gspca- videology-Rev_1.20	AGC	Y
	White Balance	N
	Shutter Speeds	15
2xK13x	Back Light Compensation	Not implemented
2xK14x	Frame Rate	30
2xK15x	Zoom	N
	Resolution	640x480
	Mirror Mode (Horizontal)	Y
	Mirror Mode (Vertical)	N
	Edge Enhancement	N
	Gamma	Y

SFT-11021 gspca_videology_Rev_ 0.21	Feature VLC	N
	AGC	N
	White Balance	N
24B1.3xUSB-C	Shutter Delay	Y
	Back Light Compensation	N
	Frame Rate	15
	Zoom	N
	Resolution	1280 X 1024
	Mirror Mode (Horizontal)	Y
	Mirror Mode (Vertical)	Y
	Edge Enhancement	N
	Exposure	Y
	Manual Gain	Y

SFT-11022 gspca_videology- Rev_1.04	Feature VLC	
	AGC	Y
	White Balance	Y
24C1.3x USB	Shutter Speed	10
Note: This camera requires a frame_offset=1	Back Light Compensation	N
	Frame Rate	15
	Zoom	N
	Resolution	
	Mirror Mode (Horizontal)	Y
	Mirror Mode (Vertical)	Y
	Edge Enhancement	N
	Gamma	Y

SFT-11023 gspca- videology- Rev_0.17.tar	Feature VLC	
	Brightness	Y
	Saturation	Y
60V002USB-C	Hue	Y
Framegrabber / Digitizer	Analog Gain(*)	Y
	Chroma Gain(*)	Y
	(*) – for Y/C input	

6. Understanding Your Camera

6.1. Theory of Operation

The host PC communicates to the Videology USB 2.0 camera through the USB Controller. The USB Controller addresses two different devices: The first device is an EEPROM, that is always in Slave mode and second, a Micro-controller that operates in Slave and Master Mode.

This architecture was chosen to minimize the time for camera communications on the USB bus. When control data from the PC is sent to the camera, it is first transferred to the EEPROM by the USB controller. Following this control data transfer the Micro-controller (in Slave mode) receives a command indicating where and how many bytes must be collected for the command. The Micro-controller interprets the data and determines what registers in the camera must be changed. At this point, the Micro-controller switches to Master mode and transfers commands and data from the EEPROM to the camera board by the I²C communication bus. Video data is sent directly to the USB Controller over a parallel bus.

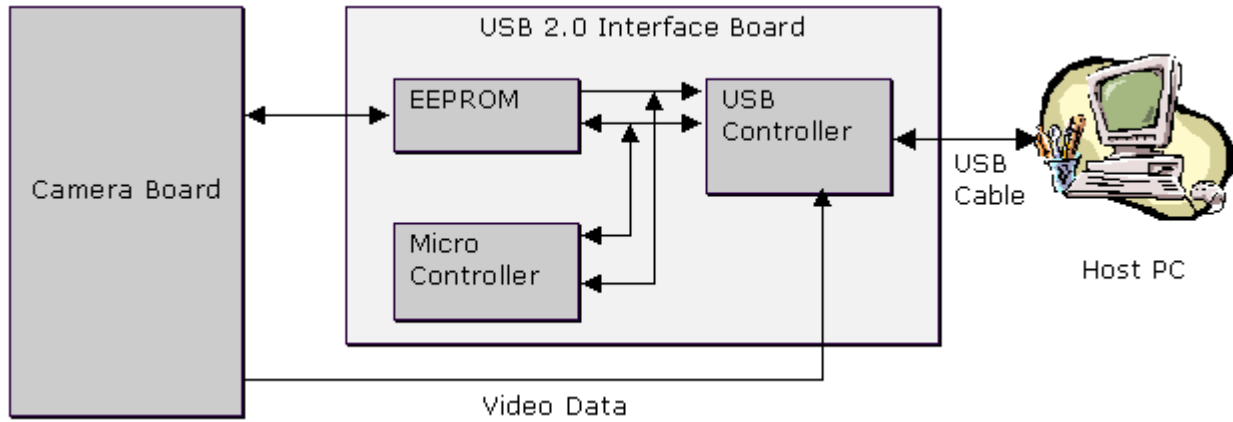

Figure 1. Block Diagram

6.2. IR/OLP Options

The Videology USB 2.0 color cameras are supplied with an IR/OLP filter that assures excellent color fidelity by blocking camera sensitive Infrared (IR) light. The IR content in certain light sources can cause the camera to produce incorrect color. The Optical Low Pass filter (OLP) part of the filter reduces color aliasing by limiting the high frequency elements of the scene to those that can be resolved by the CCD. The graph below illustrates the blocking of the IR wavelengths.

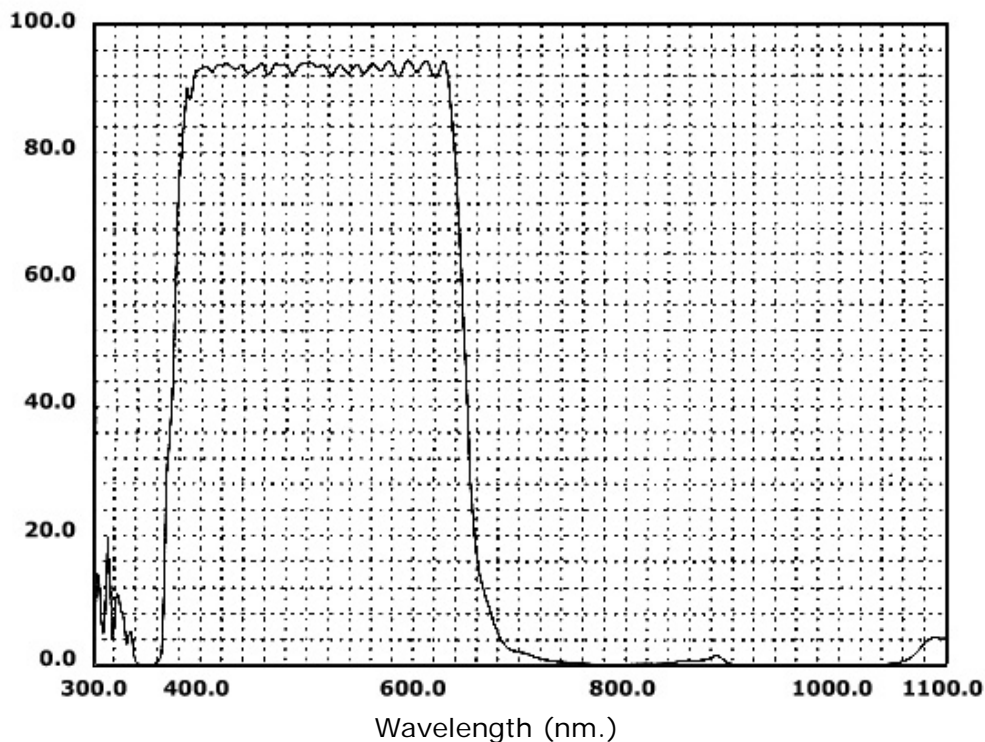
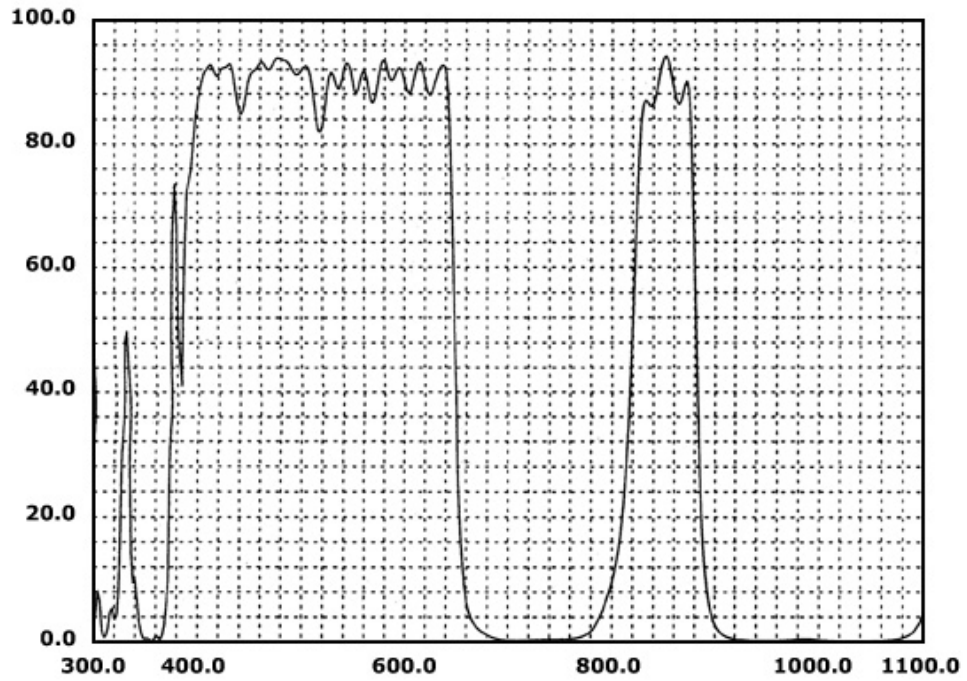

Figure 2. Normal IR/OLP Filter

The camera can alternately be supplied with an IR/OLP Day/Night filter. This type of filter functions the same as the standard filter, except that it allows a narrow band-pass in the near infrared to allow the camera to be put into a monochrome mode for better images in low lighted scenes and optimal images with near IR illumination. This option is 20K14XUSB-DN. The graph below shows the band-pass of the IR/OLP Day/ Night filter.



Wavelength (.nm)
 Figure 3. Day/night IR/OLP Filter

6.3. Glossary of Terms

6.3.1. Shutter Mode

In default mode, the camera operates in the electronic iris mode. This means the output of the CCD, which is dependent on the light intensity, is controlled by the electronics of the camera and not a mechanical iris in the lens. To do this the camera utilizes a variable integration method called an Electronic Iris that controls the CCD output. When more CCD output current is required to maintain the nominal 1 V peak to peak video output signal, then the integration period becomes longer. If too much CCD output current is occurring due to CCD sensor light saturation, then the integration period is shortened to maintain the nominal video output.

However, sometimes it is preferred that the shutter is fixed and not adjusting automatically. An example where using a fixed shutter is beneficial is if there is a very fast moving object in the scene. The longer the integration time (maximum 1/50 sec for PAL and maximum 1/60 sec for NTSC) the less sharp the image will be due to movement of the object during the integration period. To prevent this, the camera has 14 fixed shutter speeds (see table 1).

To switch the Electronic Iris off there are two options: software control or hardware control. To set the camera into the hardware control mode, set register 02h (mode out) to analog mode.

MODE	ELECTRONIC SHUTTER SPEED	
	NTSC	PAL
0	1/60 sec	1/50 sec
1	1/100 sec (flicker-less)	1/120 sec (flicker-less)
2	1/250 sec	1/250 sec
3	1/500 sec	1/500 sec
4	1/1000 sec	1/1000 sec
5	1/2000 sec	1/2000 sec
6	1/5000 sec	1/5000 sec
7	1/10000 sec	1/10000 sec
8	1/20000 sec	1/20000 sec
9	1/50000 sec	1/50000 sec
10	1/100000 sec	1/100000 sec
11	1/30 sec	1/25 sec
12	1/15 sec	1/12.5 sec
13	1/7.5 sec	1/6.25 sec
14	AUTO 1/60 to MAXIMUM_SHUTTERSPEED	AUTO 1/50 to MAXIMUM_SHUTTERSPEED
15	AUTO 1/60 to 1/100000	AUTO 1/50 to 1/100000

Table 1. Fixed Shutter Speed

Flicker-less means that a PAL camera can be used in a 60 Hz (or a NTSC camera in a 50 Hz) light environment without flickering.

6.3.2. Mirror Mode

Select by checking the mirror image box to flip the camera image horizontally.

6.3.3. Reset

Selecting the reset button sets the camera to the original factory settings. This may take a few moments depending on the speed of the PC or laptop. **Caution:** Resetting the camera will cancel all changes made by the user. In the case of the 24C1.3xUSB, the camera must be removed and the viewer restarted.

6.3.4. Gain

The camera's automatic gain control (AGC) is on by default. This function maintains the output signal at a constant level while the scene lighting changes. If the camera is pointed to gray scale staircase chart (.45 Gamma) the video signal output is normally set to 1Vp-p. This control circuit works with an integrator to create the average value of the video signal, which is then compared with an internal reference resulting in a gain increase or decrease to match the reference.

The AGC may be switched to Manual Gain Control (MGC). When the camera is in the MGC control mode, the gain can be selected by the slider bar and will not change due to light level or content changes in the scene. Moving the slider bar completely to the will also turn off the gain.

6.3.5. White Balance Mode

The camera has 4 different WB modes:

Auto mode: The camera will react continuously on changes in the scene and will adapt its Red and Blue gain to reproduce colors as well as white according to preset registers.

Beside the auto mode the camera has three default values. In these modes the camera will not change white balance in response to scene changes, but will set the white balance according to values preset in its registers.

- In Section 4.3.9, we reference the different W.B. modes.
 1. Auto white balance mode
 2. Indoor
 3. 4500 K
 4. Outdoor

7. Troubleshooting guide

Symptom 1: Video display shows a green color or pink color.

Resolution 1:

Use the frame_offset parameter to resolve

Symptom 2: Video display appears inoperable or exhibits a slow frame rate.

Resolution 2:

ISOC patch not installed in main GSPCA

Symptom 3: An incomplete or scrambled video display on USB 1.1 port.

Resolution 3:

Cameras require USB 2.0 or better to operate

Symptom 4: Cannot see video.

Resolution 4:

Driver not installed correctly.

Use the frame_offset parameter to resolve
ISOC patch not installed in main GSPCA

If problems still persist, please email the following to the address below:

support@videologyinc.com

Please include:

- Date of purchase
- Software revision number
- Camera model number
- Company name
- Contact
- Phone number
- Email address

8. Camera Specifications

8.1. 20/21K13XUSB-C

Electrical	Model	
	20K13XUSB-C EIA	21K13XUSB-C CCIR
Image Sensor	1/4" Sony Ex-View® CCD	
Active Pixels (HxV)	768 x 494	752 x 582
Frame Rate	720 x 480 Pixels (maximum USB 2.0, 30fps)	720 x 576 Pixels (maximum USB 2.0, 30fps)
Sensitivity	< 0.005 Lux (50 IRE) F1.2 3200K, lens transmission 80%, scene reflection 75%	
Signal to Noise Ratio	> 48 dB (AGC off)	
Gamma	0.45 default (1.0 via Software)	
Gain Control	Automatic 36 dB (AGC default) or Fixed options via software	
Scan Mode	Interlaced / Non-Interlaced (Selectable via software)	
Mirror Mode	Selectable via software	
Synchronization	Internal	
Back light compensation	Default on (selectable via software)	
White Balance Mode	AWB auto white mode, Fixed modes selectable via software	
Contour enhancement	Default on	
Iris Control	CCD Iris default	
Shutter Speeds	Automatic from 1/60 to 1/100,000	Automatic from 1/50 to 1/100,000
	14 fixed speeds via software	
Control Communication	Camera control via USB bus	
Power Supply	5VDC via USB bus	
Power Consumption	< 1.3W	
Environmental		
Ambient Operating Temp.	-15 °C to + 55 °C (5 °F to +131 °F)	
Ambient Operating Humidity	20% to 93%RH	
Storage Temp.	-25 °C to + 70 °C (-13 °F to +158 °F)	
Storage Humidity	To 98% RH non-condensing	
Lifetime	MTBF > 150000	
Packaging	ESD safe package	
Mechanical		
Dimensions (WxHxD)	26mm x 22mm x 16mm (1.02" x 0.86" x 0.62") (without lens Mount)	
Lens Mount	Metal CS:	20/21K138USB-C
	Metal M-12 board:	20/21K135USB-C
	Metal M-12 pinhole:	20/21K132USB-C
	Lens Choices Can Range From 1.78 ~ 16mm focal lengths	
Connectors Standard:	Power/ Data	USB
Power over USB bus	+5VDC available to power 20/21K13 series cameras	
Connectors	Board to board connectors: camera to USB board	
	USB connector: power & data	
Software		
Twain and DirectX compatible software drivers		
Control of camera features thru USB ports:		
	White balance	Shutter modes
	Mirror mode	Back light compensation
	Gain	Edge enhancement
SDKs are available for OEMs		
Data rate	480 Mb/sec. (maximum)	
	Distance 5m	
	With /repeater 30m	

8.2. 20/21K14XUSB-C

Electrical	Model	
	20K14XUSB-C NTSC	21K14XUSB-C PAL
Image Sensor	1/4" IL Color CCD	
Active Pixels (HxV)	510 x 492	500 x 582
Horizontal resolution	≥330 TVL	
Frame Rate	720 x 480 Pixels (maximum USB 2.0, 30fps)	720 x 576 Pixels (maximum USB 2.0, 30fps)
Sensitivity	< 0.5 Lux (50 IRE) F1.2 3200K, lens transmission 80%, scene reflection 75%	
Signal to Noise Ratio	> 48 dB (AGC off)	
Gamma	0.45 default (1.0 via Software)	
Gain Control	Automatic 36 dB (AGC default) or Fixed options via software	
Scan Mode	Interlaced / Non-Interlaced (Selectable via software)	
Mirror Mode	via software	
Synchronization	Internal Selectable	
Back light compensation	Default on (selectable via software)	
White Balance Mode	AWB auto white mode, Fixed modes selectable via software	
Contour enhancement	Default on	
Iris Control	CCD Iris default	
Shutter Speeds	Automatic from 1/60 to 1/100,000	Automatic from 1/50 to 1/100,000
	14 fixed speeds via software	
Control Communication	Camera control via USB bus	
Power Supply	5VDC via USB bus	
Power Consumption	< 1.3W	
Environmental		
Ambient Operating Temp.	-15 °C to + 55 °C (5 °F to +131 °F)	
Ambient Operating Humidity	20% to 93%RH	
Storage Temp.	-25 °C to + 70 °C (-13 °F to +158 °F)	
Storage Humidity	To 98% RH non-condensing	
Lifetime	MTBF > 150000	
Packaging	ESD safe package	
Mechanical		
Dimensions (WxHxD)	26mm x 22mm x 16mm (1.02" x 0.86" x 0.62") (without lens Mount)	
Lens Mount	Metal CS:	20/21K148USB-C
	Metal M-12 board:	20/21K145USB-C
	Metal M-12 pinhole:	20/21K142USB-C
	Lens Choices Can Range From 1.78 ~ 16mm focal lengths	
Connectors Standard:	Power/ Data	USB
Power over USB bus	+5VDC available to power 20/21K14 series cameras	
Connectors	Board to board connectors: camera to USB board	
	USB connector: power & data	
Software		
Twain and DirectX compatible software drivers		
Control of camera features thru USB ports:		
	White balance	Shutter modes
	Mirror mode	Back light compensation
	Gain	Edge enhancement
SDKs are available for OEMs		
Data rate	480 Mb/sec. (maximum)	
	Distance	5m
	With / repeater	30m

8.3. 20/21K15XUSB-C

Electrical	Model	
	20K15XUSB-C NTSC	21K15XUSB-C PAL
Image Sensor	1/4" IL Color CCD	
Active Pixels (HxV)	768 x 494	752 x 582
Viewer Display	720 x 480 Pixels (maximum USB 2.0, 30fps)	720 x 576 Pixels (maximum USB 2.0, 30fps)
Sensitivity	< 0.5 Lux (50 IRE) F1.2 3200K, lens transmission 80%, scene reflection 75%	
Signal to Noise Ratio	> 48 dB (AGC off)	
Gamma	0.45 default (1.0 via Software)	
Gain Control	Automatic 36 dB (AGC default) or Fixed options via software	
Scan Mode	Interlaced / Non-Interlaced (Selectable via software)	
Mirror Mode	via software	
Synchronization	Internal Selectable	
Back light compensation	Default on (selectable via software)	
White Balance Mode	AWB auto white mode, Fixed modes selectable via software	
Contour enhancement	Default on	
Iris Control	CCD Iris default	
Shutter Speeds	Automatic from 1/60 to 1/100,000	Automatic from 1/50 to 1/100,000
	14 fixed speeds via software	
Control Communication	Camera control via USB bus	
Power Supply	5VDC via USB bus	
Power Consumption	< 1.3W	
Environmental		
Ambient Operating Temp.	-15 °C to + 55 °C (5 °F to +131 °F)	
Ambient Operating Humidity	20% to 93% RH non-condensing	
Storage Temp.	-25 °C to + 70 °C (-13 °F to +158 °F)	
Storage Humidity	To 98%RH	
Lifetime	MTBF > 150000	
Packaging	ESD safe package	
Mechanical		
Dimensions (WxHxD)	26mm x 22mm x 16mm (1.02" x 0.86" x 0.62") (without lens Mount)	
Lens Mount	Metal CS:	20/21K158USB-C
	Metal M-12 board:	20/21K155USB-C
	Metal M-12 pinhole:	20/21K152USB-C
	Lens Choices Can Range From 1.78 ~ 16mm focal lengths	
Connectors Standard:	Power/ Data	USB
Power over USB bus	+5VDC available to power 20/21K15 series cameras	
Connectors	Board to board connectors: camera to USB board	
	USB connector: power & data	
Software		
Twain and DirectX compatible software drivers		
Control of camera features thru USB ports:		
	White balance	Shutter modes
	Mirror mode	Back light compensation
	Gain	Edge enhancement
SDKs are available for OEMs		
Data rate	480 Mb/sec. (maximum)	
	Distance	5m
	With / repeater	30m

8.4. 24B1.3xUSB-C

Electrical		24B1.3xUSB-C	
CCD Sensor	1/2" CMOS 6.8mm x 5.4mm array		
Active Pixels (HxV)	1280 x 1024, 5.2um square Pixels		
Frame Rate	1280 x 1024 Pixels –un-compressed 24fps 640 x 480 Pixels un-compressed – 30fps		
Sensitivity	< 1.0 Lux (50 IRE) F1.2 3200K, lens transmission 80%, scene reflection 75%		
Signal to Noise Ratio	> 45 dB (AGC off)		
Gamma	0.45 default (1.0 via Software)		
Gain Control	Automatic 36 dB (AGC default) or Fixed options via software		
Scan Mode	Progressive Scan		
Mirror Mode	Selectable via software		
Synchronization	Internal crystal controlled		
Back light compensation	Default on (selectable via software)		
White Balance Mode	AWB auto white mode, Fixed modes selectable via software		
Contour enhancement	Default on		
Iris Control	Progressive Scan		
Shutter Speeds	Automatic from 1/2 to 1/5,000 seconds 14 fixed speeds via software		
Control Communication	Camera control via USB bus		
Power Supply	5VDC via USB bus		
Power Consumption	<110 mA, < 0.6W		
Environmental			
Ambient Operating Temp.	-15 °C to + 55 °C (5 °F to +131 °F)		
Ambient Operating Humidity	20% to 93%RH		
Storage Temp.	-25 °C to + 70 °C (-13 °F to +158 °F)		
Storage Humidity	To 98% RH non-condensing		
Lifetime	MTBF > 150000		
Packaging	ESD safe package		
Mechanical			
Dimensions (WxHxD)	32 mm x 32mm x 7.7mm (1.26" x 1.26" x 0.30") (without lens Mount)		
Lens Mount	Metal CS:	24B1.38-USB-C	
	Metal M-12 board:	24B1.35-USB-C	
	Lens Choices Can Range From 1.78 ~ 16mm focal lengths		
Connectors Standard:	Power/ Data	USB	
Power over USB bus	+5VDC available to power 24B1.3X series cameras		
Connectors	Board to board connectors: camera to USB board USB connector: power & data		
Software			
Twain and DirectX compatible software drivers			
Control of camera features thru USB ports:			
	White balance	Shutter modes	
	Mirror mode	Back light compensation	
	Gain	Edge enhancement	
SDKs are available for OEMs			
Data rate	480 Mb/sec. (maximum)		
	Distance 5m		
	With / repeater 30m		

8.5. 24C1.3USB

Electrical	24C1.3USB	
Image Sensor	1/3" CMOS	
Resolution (HxV)	1280 x 1024	
Max. Frame Rate	12.5 – 15fps @ SVGA	
Sensitivity	< 2.0 Lux (50 IRE) F1.2 3200K, lens transmission 80%, scene reflection 75%	
Signal to Noise Ratio	> 45 dB (AGC off)	
Gamma	0.45 default (1.0 via Software)	
Gain Control	Automatic 36 dB (AGC default) or Fixed options via software	
Scan Mode	Progressive Scan	
Mirror Mode	Selectable via software	
Synchronization	Internal Selectable	
Back light compensation	Default on (selectable via software)	
White Balance Mode	AWB auto white mode, Fixed modes selectable via software	
Contour enhancement	Default on	
Iris Control	Electronic Shutter	
Shutter Speeds	Automatic from 1/5 to 1/10,000 second	
	14 fixed speeds via software	
Control Communication	Camera control via USB bus	
Power Supply	5VDC via USB bus \pm 5% (Not polarity protected)	
Power Consumption	< 0.6W	
Environmental		
Ambient Operating Temp.	-15 °C to + 55 °C (5 °F to +131 °F)	
Ambient Operating Humidity	20% to 93%RH	
Storage Temp.	-25 °C to + 70 °C (-13 °F to +158 °F)	
Storage Humidity	To 98% RH non-condensing	
Lifetime	MTBF > 150000	
Packaging	ESD safe package	
Mechanical		
Dimensions (WxHxD)	26mm x 22mm x 16mm (without lens Mount)	
Lens Mount	Metal CS:	24C1.38USB
	Metal M-12 board:	24C1.35USB
	Lens Choices Can Range From 1.78 ~ 16mm focal lengths	
Connectors Standard:	Power/ Data	USB
Power over USB bus	+5VDC available to power	
Connectors	Board to board connectors: camera to USB board	
	USB connector: power & data	
Software		
Twain and DirectX compatible software drivers		
Control of camera features thru USB ports:		
	White balance	Shutter modes
	Mirror mode	Back light compensation
	Gain	Edge enhancement
SDKs are available for OEMs		
Data rate	480 Mb/sec. (maximum)	
	Distance 5m	
	With / repeater 30m	

8.6. 60V002USB-C

Electrical	60V002USB-C	
Video Input	CVBS or Y/C	
Video Output	USB 2.0	
Power Consumption	350mA	
Camera Power Supply Feed Through	5VDC or 3.3VDC up to 200mA unregulated	
Mechanical		
Dimensions (WxHxD)	42mm x 42mm x 0.6mm (1.6" x 1.6" x 0.23")	
Weight	11.33g (0.025 lbs)	
Software		
Viewer (included) SFT-07019	<ul style="list-style-type: none"> • WDM device drivers • DirectX/DirectShow compliant • TWAIN compliant (requires driver installation) 	
SDK (optional) SFT-07019-SDK	Complete software development kit and support for OEMs	
Recommended System Requirements		
Hardware	Pentium IV 2.3GHz +, 1GB hard drive, Intel USB 2.0 Host controller	
Software	Windows 7 32 bit and 64 bit	
	Windows Vista 32 bit and 64 bit	
	Windows XP Service pack 2 +, DirectX 9.0c or above	
Standards		
	RoHS	

9. Contact Information

For technical assistance with this product, please contact the supplier from whom the product was purchased.

For OEM inquiries, contact Videology Imaging Solutions:

North / South America:	Europe:
Videology Imaging Solutions Inc. 37M Lark Industrial Parkway Greenville, RI 02828 USA Tel: (401) 949-5332 Fax: (401) 949-5276	Videology Imaging Solutions Europe Neutronenlaan 4 NL-5405 NH Uden, Netherlands Tel: +31 (0) 413 256 261 Fax: +31 (0) 413 251 712

Please visit our website at: <http://www.videologyinc.com>

VIDEOLOGY IMAGING SOLUTIONS is an ISO 9001 registered video camera developer and manufacturer serving industrial, machine vision, biometric, security, and specialty OEM markets. Videology designs, develops, manufactures, and distributes video, image acquisition, and display technologies and products to OEMs worldwide.